

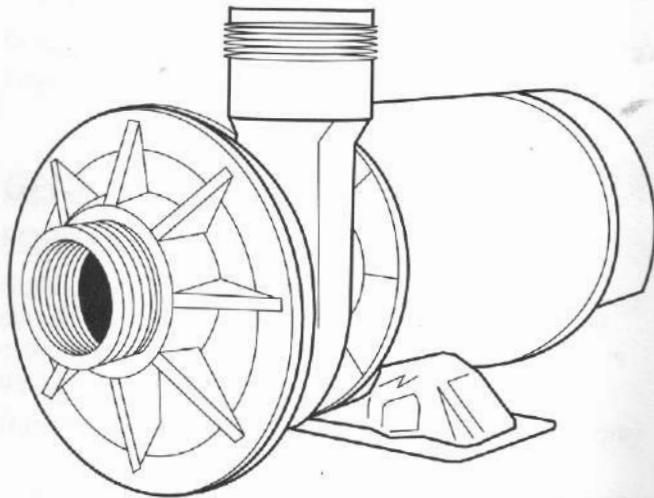

Franklin Pump Systems

A-Series Pump OWNER'S MANUAL



BEFORE INSTALLING PUMP, BE SURE TO READ THIS OWNER'S MANUAL CAREFULLY.

REFER TO PRODUCT DATA PLATE(S) FOR ADDITIONAL OPERATING INSTRUCTIONS AND SPECIFICATIONS.

CAUTION Do not run mechanical shaft seals dry. Fill pump with water before starting or pump will be damaged. The motor on this pump is guaranteed by the manufacturer and in event of failure it must be returned to an authorized service station for repairs. Motor warranty is void if repairs aren't made by an authorized repair station.

Most water system troubles result from improper installation. We therefore suggest that you read this manual carefully before starting your pump. The "SERVICE CHECK LIST" will assist you in locating and eliminating the cause of any trouble you may encounter later. Check and make available all the tools you will need to install your pump. These are wrenches, pipe sealant, pipe fittings and nipples, screwdriver, etc. Be sure to have available the proper and adequate wiring material.

INSPECT THE SHIPMENT

All pumps are carefully tested, crated and inspected to insure their arrival in good condition. Occasionally, products may become damaged during shipment.

When the pump is received, examine it closely to make sure there is no damage or broken parts. If damage is evident, report this fact immediately to either the carrier who made the shipment or to the dealer from which the pump was purchased. All pumps are water-tested prior to shipment. If water film is found, it is the result of this testing.

READ AND FOLLOW SAFETY INSTRUCTIONS

! This is the safety alert symbol. When you see this symbol on your pump or in this manual, look for one of the following signal words and be alert to the potential for personal injury:

DANGER warns about hazards that will cause serious personal injury, death or major property damage if ignored.

WARNING warns about hazards that can cause serious personal injury, death or major property damage if ignored.

CAUTION warns about hazards that will or can cause minor personal injury or major property damage if ignored.

The label **NOTICE** indicates special instructions, which are important but not related to hazards.

! WARNING



Hazardous voltage. Can shock, burn, or cause death.

Ground pump before connecting to power supply. Disconnect power before working on pump, motor or tank.

Carefully read and follow all safety instructions in this manual and on pump.

Keep safety labels in good condition.

Replace missing or damaged safety labels.

! **Wire motor for correct voltage. See "Electrical" section of this manual and motor nameplate.**

! **Ground motor before connecting to power supply.**

! **Meet National Electrical Code, Canadian Electrical Code, and local codes for all wiring.**

! **Follow wiring instructions in this manual when connecting motor to power lines.**

INSTALLATION LOCATION

Locate pump as close to application as possible preferably in a dry, well ventilated area away from direct sunlight. It should be on a hard, level surface.

1. Drainage- away from pump
2. Ventilation of pump motor
3. Access for future servicing and winterizing
4. Protection from the elements

Pumps are designed for flooded suction (i.e. the pump's suction is below water level.)

GENERAL PLUMBING

FOR SOLVENT WELD CONNECTIONS

Rigid or flexible PVC pipe can be used. Pipe ends should be clean and free of any flash caused by the cutting operation. Be sure that the proper adhesive is used on the type of pipe specified.

Recommended Adhesives- These are examples only and are not intended to restrict brands.

PVC-PVC Joint	PVC-ABS Joint
Uni-Weld Pool-Tite 2000	Uni-Weld Pool-Tite 2000
Sureguard Flex 20	Sureguard Wel-All No.5
IPS Weld-On 705	IPS Weld-On 794

NOTE: A primer will assure that joints are water tight.

CAUTION We recommend that you consider climatic conditions when applying adhesives. Certain atmospheric situations, such as high moisture content, make the adhesive action of certain glues less effective. Check the manufacturer's instructions.

FOR THREADED CONNECTIONS

Use only Teflon tape or equivalent on threaded plumbing connections. Other pipe compounds may damage threads. We do not recommend the use of silicone or petroleum based compounds.

DO NOT OVER TIGHTEN. FOR ALL PLASTIC JOINTS, WE RECOMMEND YOU HAND TIGHTEN THEN AND GIVE THEM AN ADDITIONAL 1/2 TURN WITH A WRENCH.

PUMP PLUMBING

Suction pipe should be as large or larger than the discharge pipe. Avoid using a suction pipe smaller than the pump intake.

Keep the piping as straight and short as possible. Avoid connecting an elbow directly into the pump inlet (use a length of straight pipe to allow a proper entry for the water). Arrange horizontal runs to slope upward to the pump to prevent high spots that could form air pockets. Support the piping independently so that it places no strain on the pump. Keep as much of the suction line as possible below the water-level to reduce priming time. Install valves and unions in the pump suction and return lines to facilitate servicing. Valves are recommended for throttling the pump discharge. The valves are essential for pump maintenance if the system is installed below deck level. Suction valves are essential for priming all pumps without strainer bodies installed above water level. We recommend the use of a check valve in the suction pipe at or below the water level.

ELECTRICAL INSTRUCTIONS

Refer to information on motor nameplate for electrical service data. All motors should have fused disconnect switch or circuit breaker. Be sure wire size is sufficient for pump HP and distance from power source. Wiring should be done in accordance with applicable codes by a competent electrician.

CAUTION We recommend the installation of a Ground Fault Circuit Interrupter (GFCI) for maximum safety.

PUMP START-UP

Do not operate pump until it has been primed as water acts to cool and lubricate the seal. For pumps located above the water line, close the suction line valve and fill pump with water in order to prime. Pumps located below water level will self-prime if all piping is also below water level. After pump has been primed, energize motor and open all suction and discharge line valves. It may take some time for pump to remove air from the suction lines. If no flow is observed in five minutes, stop the motor and reprime. If the pump fails to operate, check for air leaks. Refer to troubleshooting section.

After about 10 minutes of operation, check the return fittings for air bubbles. A continuous flow of air indicates leaks in the suction line. Locate and correct any leaks immediately.

CONTROLLING THE OUTPUT

Keep the gate valve in the suction line fully open during operation. Should it be necessary to control the output, use a valve in the return line.

CAUTION Do not operate pump with closed suction or discharge valves.

TWO-SPEED PUMPS

In spas and hot tubs, use high speed to attain full performance in the hydro-therapy mode. At other times, such as filter / heat cycle mode, use low speed. Low speed provides sufficient flow to activate most spa heaters and provides sufficient flow for filtration.

NOTE: Two-speed pumps must be in high speed mode to prime.

WINTERIZING

Consult your dealer for advice on winterizing your equipment if freezing temperatures occur in your locality. His knowledge of your equipment makes him the best qualified source of information. Follow his recommendations drain system by loosening drain plugs (drain plugs will drain without completely removing plug from unit) and/or removing pipe caps.

WATER CHEMISTRY

A proper and consistent use of chemicals is necessary to maintain clean, sanitary water, prevent a spread of germ infection and control the growth of algae which can spoil the appearance and enjoyment of your spa.

Chlorine is the most commonly used chemical to provide clean, sanitary water. Either dry or liquid chlorine (calcium or sodium hypochlorite) can be used which should be added daily as it is dissipated by dirt and germs as well as by the sun and wind.

It is also important that the correct level of acidity or alkalinity of the pool water be maintained. This is measured in pH, a pH reading of 7.0 is considered neutral. Readings above pH 7.0 are alkaline and readings below are acid. A desirable range is 7.2 to 7.4.

PUMP MAINTENANCE

1. Motors are self-lubricating.
2. Visually inspect motor for blockage of air vents on motor shell. Remove any debris after shutting off breaker.
3. Shaft seals may become worn and must be replaced if leakage is observed.

SERVICE AND REPAIR PARTS

Refer all service to your local dealer as his knowledge of your equipment makes him the best qualified source of information. Order all repair parts through your dealer. Give the following information:

1. Unit Nameplate data
2. Description of part

TROUBLESHOOTING

A. Motor does not start

1. Disconnect switch or circuit breaker in OFF position.
2. Fuses blown or thermal overload open.
3. Locked motor shaft.
4. Motor windings burned out.
5. Defective starting switch inside single-phase motor.
6. Disconnected or defective wiring.
7. Low voltage

B. Motor does not reach full speed

1. Low voltage.
2. 2 speed model set on low speed.
3. Motor windings connected for wrong voltage on dual voltage motor.

C. Motor overheats (protector trips)

1. Low voltage.
2. Motor windings connected for wrong voltage on dual voltage motor.
3. Inadequate ventilation.

D. Pump delivers no water

1. Pump is not primed.
2. Closed valve in suction or discharge line.
3. Leakage of air into suction system.
4. Impeller clogged.

E. Low pump capacity

1. Valve in suction or discharge line partly closed.
2. Suction or discharge line partly plugged.
3. Suction or discharge line too small.
4. Pump running at reduced speed (see above).
5. Impeller clogged.
6. Wrong rotation (3-phase only).

F. Low pump pressure

1. Pump running at reduced speed.
2. Wrong rotation (3-phase only).
3. Discharge valve or inlet fittings open too wide.

G. High Pump Pressure

1. Discharge valve or inlet fitting closed too much.
2. Return lines too small.

H. Noisy pump and motor

1. Worn motor bearings.
2. Valve in suction line partly closed.
3. Suction line partly plugged.
4. Vacuum hose plugged or too small.
5. Pump not supported properly.

I. Leakage of water at shaft

1. Shaft seal requires replacement.

J. Air bubbles at inlet fittings

1. Leakage of air into suction line at connection or valve stem.
2. Restriction in suction line.
3. Low water level.

NOTE: If the recommendations in the TroubleShooting portion of this Owner's Manual do not solve your particular problem(s), please contact your local dealer for service.

PARTS FOR MODELS A & RSPA SERIES

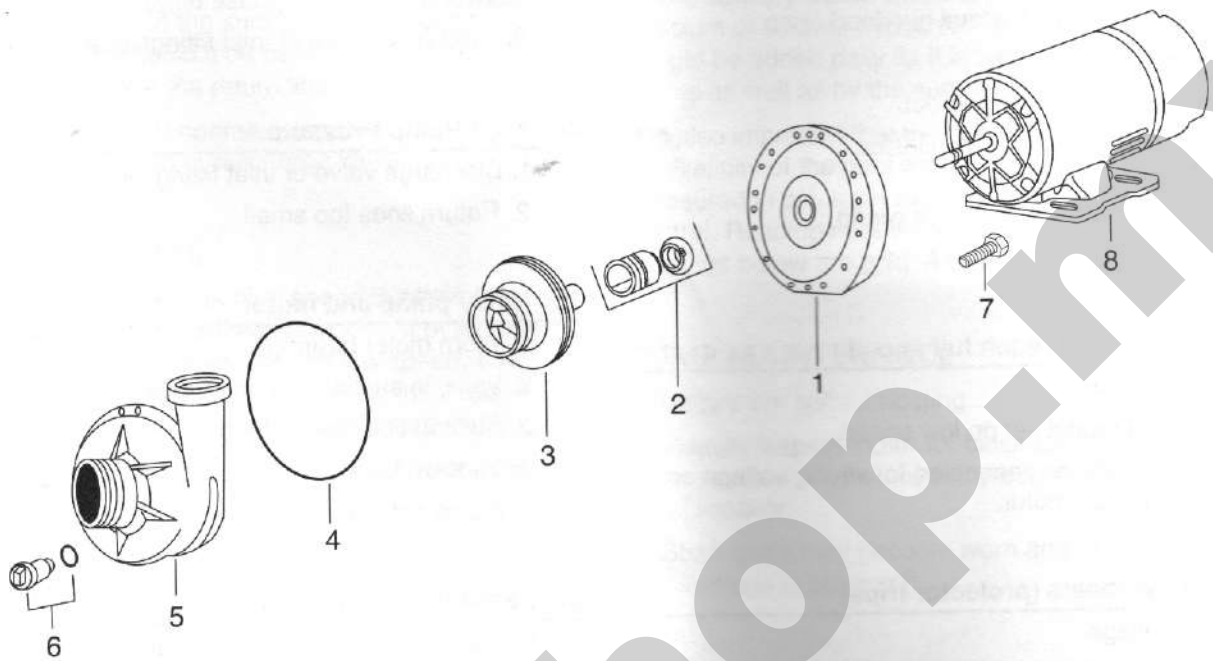

Figure No.	Part No.	Description
1	02-1684-09-R	Bracket SA Spa Pump
2	10-0002-06	Mechanical Shaft Seal 5/8
3	05-1500-15-R	S2A Impeller 3.875D #11433
	05-2000-20-R	S35A Impeller 3.875D #11434
	05-2000-25-R	S3A Impeller 3.75D #11434
	05-3000-30-R	S4A Impeller 3.875D #11435
	05-0365-04-R	S45A Impeller 4.20D
4	47-0258-53-R	Sq. Ring 6-1/8 x 1/8 Ntrl
5	03-0872-03-R	Case Assy. SA Spa Pump w/ plug
	03-0889-03-R	Case Assy. S45A
6	31-1609-06-R	1/4 plug w/ O-ring (47-0112-00)
7	14-4379-02-R	Screws 10-12 x 1 Phil Pan HD SS
8	Motor	Motor Selection see index for page no.